



A registered trademark of SNA Europe Group

Auto News



- ▶ Engine & Plug Tools
- ▶ Brake Tools
- ▶ Transmission & Wheel Tools
- ▶ Suspension Tools
- ▶ Body Work
- ▶ Exhaust Tools
- ▶ Oil Change Tools



As an extension of our recently launched automotive program, Bahco takes a step forward in the development of tools suitable for passenger cars as well as for heavy vehicles.

We extend our current offer by releasing a large range of special tools for Engine and Plug applications, Transmission and Wheels, Brakes, Oil Changing applications, Exhaust, Suspension and Bodywork further reinforcing Bahco as a supplier to the automotive aftermarket.

Keeping maximum efficiency and comfort in mind, our tools fit our modular system, making them compatible with our tool trolley range.

The foam inlays, which follow the T-Module System, are supplied in blow mould cases with metal latch locks for increased security. The blow mould plastic boxes also feature holes so that the user can lock them.

Bahco strives to be the complete supplier of tools and instruments for the automotive industry and repair workshops. This is our contribution to professional pride and expertise.



ICON INDEX



Product Code



Parcel Dimensions (mm)



Package Quantity



Product Weight (kg)



EAN Code

01 ENGINE & PLUG TOOLS 5



- Spark plug thread restorer.....6
- Glow plug thread repairing set.....6
- Glow plug chamber cleaning set.....7
- Glow plug puller.....7
- Diesel injector seat cutter8
- Injection nozzle socket set, 25-27-29-30 mm.....9
- Diesel injector washer puller9
- Sliding hammer / washer and wiper puller.....10
- Copper injector sealing ring set.....10
- Common rail 8 injectors fuel return tester11
- Engine oil pressure tester set.....12
- Seal and soft hose removal and picking tool set.....13
- Hose clamp metallic14
- Hose clamp pliers set.....14
- Quick fluid stopper and injector hose separator set.....15
- Cooling system pressure tester set.....16/17
- Cooling system refiller, vacuum.....18
- Universal twin cam locking tool19
- Crankshaft and camshaft seal installer set.....19
- Clutch alignment rectifier.....20
- Gasket joints separator set21
- Stud remover installer set.....22
- AC repairing tool set.....22
- TORX® Tamper 1/2" socket with bit, suitable for engines.....23
- Ribe 1/2" socket with bit, suitable for engines23
- Xzn 1/2" socket with bit, suitable for engines.....24

02 BRAKE TOOLS..... 25

- TORX® 1/2" impact socket bit set for brakes.....26
- XZN 1/2" impact socket bit set for brakes26
- 1/2" pentagon socket and bit set for hand brake.....27
- Shoe brake springs removing and installation set.....28/29



03 TRANSMISSION & WHEEL TOOLS 31



- Bearing removing and installing set32
- Multi positioning ratcheting pry bar set33
- 1/2" impact socket and bit set33

04 SUSPENSION TOOLS..... 35

- MacPherson spring compressor device.....36
- Wishbone lever tool.....37



05 BODY WORK TOOLS & EXHAUST TOOLS 39



- Wiper puller set40
- Universal exhaust removing tool41

06 OIL CHANGE TOOLS..... 43

- Oil drainer and refiller with chamber44
- Oil drain plug restorer set45
- Mini oil drain plug restorer sets46



01

**ENGINE
& PLUG
TOOLS**



▶ SPARK PLUG THREAD RESTORER

- Application: For repair of stripped or damaged spark plugs threads and spark plug seats
- Contents:
 - Tap: M14 x 1,25P [BE110014]
 - Step tap: M14 x 1,25P - M15,8 x 1,25P [BE110015]
 - Seat cutter [BE110001]
 - Wrench for taps [BE110002]
 - Insert drive [BE110038]
 - Hex key, 2,5 mm
 - Insert/coils M14:
 - 10 units with length 9,4 mm
 - 10 units with length 15 mm
- Three step operation:
 - Expand the thread area by passing the tap
 - Clean the area with the seat cutter by passing it several times
 - Insert glued coil
- Supplied in a blow mould case, in foam inlay modular size T6
 Fits into the Bahco T- module inlay system for tool trolleys!

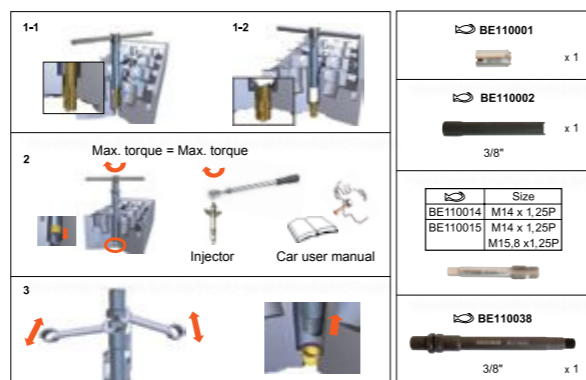
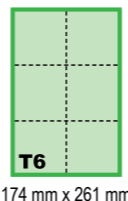

COMPONENTS AND SPARE PARTS

- BE110014 / Tap: M14 x 1,25P
- BE110015 / Step tap: M14 x 1,25P - M15,8 x 1,25P
- BE110001 / Seat cutter
- BE110002 / Wrench for taps
- BE110038 / Insert drive



▶ GLOW PLUG THREAD REPAIRING SET

- Application: For repairing / restoring 8 mm and 10 mm damaged glow plug threads
- Contents:
 - Fitting rod
 - Plug end blanks:
 - M8 and M10
 - Taps:
 - M8 x 1,0
 - M10 x 1,0
 - M10 x 1,25
 - Insert fitting tool
 - M8 x 1,0 - M10 x 1,0
 - M10 x 1,25 - M12 x 1,25
 - Inserts / coils:
 - 1 x M8 x 1,0
 - 1 x M10 x 1,0
 - 1 x M10 x 1,25
- Supplied in a blow mould case, in foam inlay for a better tool control



Taps	x 3	M8 1,0 x 69L M10 1,0 x 69L M10 1,25 x 69L
Inserts/coils	x 3	M8 x 1,0 M10 x 1,0 M10 x 1,25
Plug end blanks	x 2	M8 M10
Fitting rod	x 1	Ø3 x M3
Insert fitting tool	x 2	M8 x 1,0 - M10 x 1,0 M10 x 1,25 - M12 x 1,25

COMPONENTS AND SPARE PARTS

- BE1210P11 / Taps, Inserts / coils and Plug end blanks



▶ GLOW PLUG CHAMBER CLEANING SET

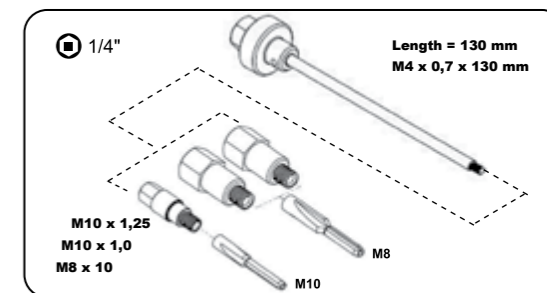

- Application: Reams and cleans the bore of the glow plug aperture and the sealing seat when replacing the glow plugs
- For 8 mm and 10 mm glow plugs
- Contents:
 - Extension bar M4 x 0,7 x 130 mm
 - Reamers: M8 and M10
 - Reamer guides: M8 x 1,0P, M10 x 1,0P and M10 x 1,25P
- Operation:
 - Remove glow plug
 - Clean the thread area with the reamer
 - Can be used individually or with a 1/4" ratchet
- Supplied in a blow mould case, in foam inlay for a better tool control



COMPONENTS AND SPARE PARTS

- BE1200P6AC1 / Reamers [M8 and M10] and Reamer guides [M8 x 1,0P, M10 x 1,0P and M10 x 1,25P]



▶ GLOW PLUG PULLER



- Application: Once the glow plug has been unscrewed, BE1205 allows to extract 9 mm and 10 mm units in difficulties to access places and/or where there is a lack of space between the glow plug and cylinder head
- Contents: 1 puller
- Operation: The glow plug is taken from its head and pulled out using the 6 mm and 19 mm hex screw



► DIESEL INJECTOR SEAT CUTTER

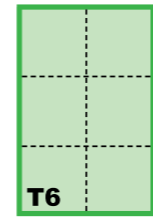

174 mm x 261 mm



- Application: To clean the injector seat to ensure that it has the correct dimension when replacing or reworking the injector
- Contents:
 - T-handle [BE1315P71]
 - Centering guide [BE1315P72]
 - Cutters:
 - 15 x 19 mm flat cutter for various car brands [BE1315P73]
 - 17 x 17 mm angled cutter for various car brands [BE1315P74]
 - 17 x 17 mm flat cutter for BMW, PSA, Renault etc [BE1315P75]
 - 17 x 19 mm flat cutter for Mercedes CRD engines etc [BE1315P76]
 - 17 x 21 mm angled cutter for Fiat Group, Iveco etc [BE1315P77]
- Supplied in a blow mould case, in foam inlay modular size T6. Fits into the Bahco T-module inlay system for tool trolleys

COMPONENTS AND SPARE PARTS

- BE1315P71 / T-handle
- BE1315P72 / Centering guide
- BE1315P73 / 15 x 19 mm flat cutter for various car brands
- BE1315P74 / 17 x 17 mm angled cutter for various car brands
- BE1315P75 / 17 x 17 mm flat cutter for BMW, PSA, Renault etc
- BE1315P76 / 17 x 19 mm flat cutter for Mercedes CRD engines etc
- BE1315P77 / 17 x 21 mm angled cutter for Fiat Group, Iveco etc



► INJECTION NOZZLE SOCKET SET, 25-27-29-30 MM

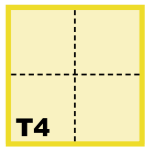

174 mm x 174 mm



- Application: For installing and removing injection nozzles
- Contents:
 - 1/2" drive hex sockets with window in 4 sizes: 25 mm, 27 mm, 29 mm and 30 mm
- Suitable for Bosch, Siemens. Can be also used on PSA 2.0HDI engines [110 / 135 HP]
- Supplied in a blow mould case, in foam inlay modular size T4. Fits into the Bahco T-module inlay system for tool trolleys



► DIESEL INJECTOR WASHER PULLER



- Application: To remove / install the copper washers of diesel injectors
- Enables a quick, easy and safe removal/installation
- The length of 230 mm allows to work on deeply seated injectors
- New copper washers: BE1305P450 / Copper injector sealing ring set, 450 pcs [see page 10]

▶ SLIDING HAMMER / WASHER AND WIPER PULLER



- Application: Allows you to pull with force, included in BBS170P13 / Wiper puller set, 13 pcs and can be used with BE1300 / Diesel injector washer puller
- Features a quick tightening / adjusting system
- Weight: 1,22 kg
- Length: 235 mm



▶ COPPER INJECTOR SEALING RING SET



- Application: To install in the diesel injector, after having removed the old damaged washer/s or when changing injectors
- Contents: 450 pcs of washers / sealings / rings in copper
- Adapt the amount of washers installed in order to have the injector in the correct position in the chamber



▶ COMMON RAIL 8 INJECTORS FUEL RETURN TESTER

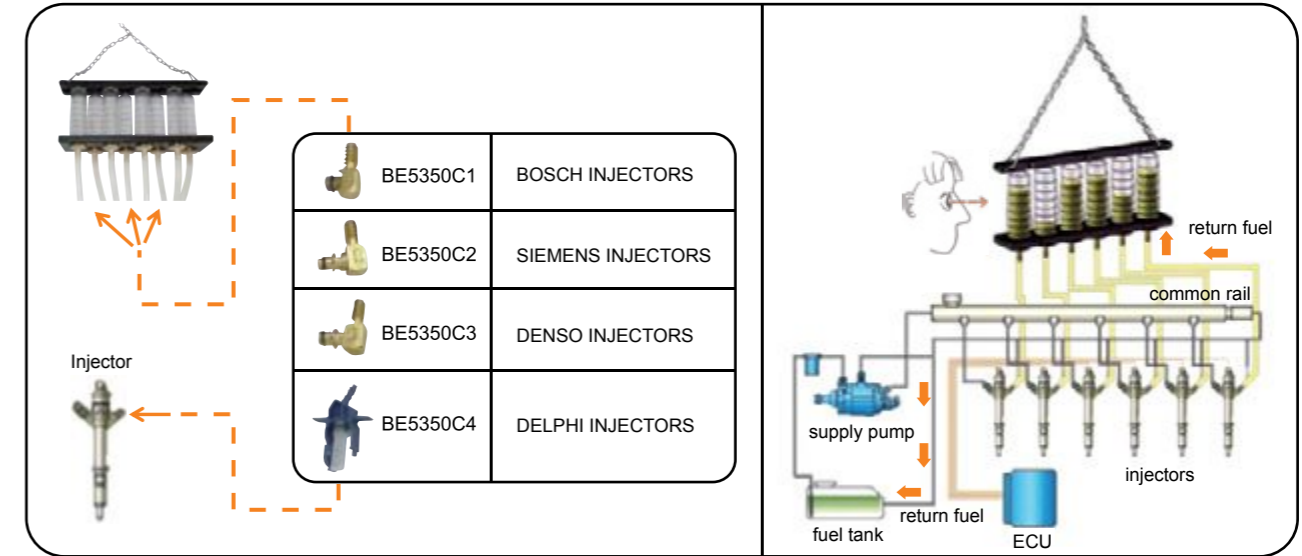

- Application: To be used on the injector return side of a common rail system in order to verify if the diesel injector is working properly, by checking the fluid return [ensure that the injectors are supplying the correct quantity of diesel]
- Contents:
 - Main device [with 8 cylinders]
 - 8 injector connectors per each injector maker [Bosch, Delphi, Denso, Siemens]. All the connectors are also available as spare parts
- Graduated polycarbonate bottles makes it easy to read and compare the cylinders, can be used on vehicle engines up to 8 cylinders
- Fuel resistant and very flexible silicon hoses
- Supplied in a blow mould case, in foam inlay for a better tool control

COMPONENTS AND SPARE PARTS

- BE5350C1 / 8 Connectors for Bosch Injectors
- BE5350C2 / 8 Connectors for Siemens Injectors
- BE5350C3 / 8 Connectors for Denso Injectors
- BE5350C4 / 8 Connectors for Delphi Injectors



▶ ENGINE OIL PRESSURE TESTER SET

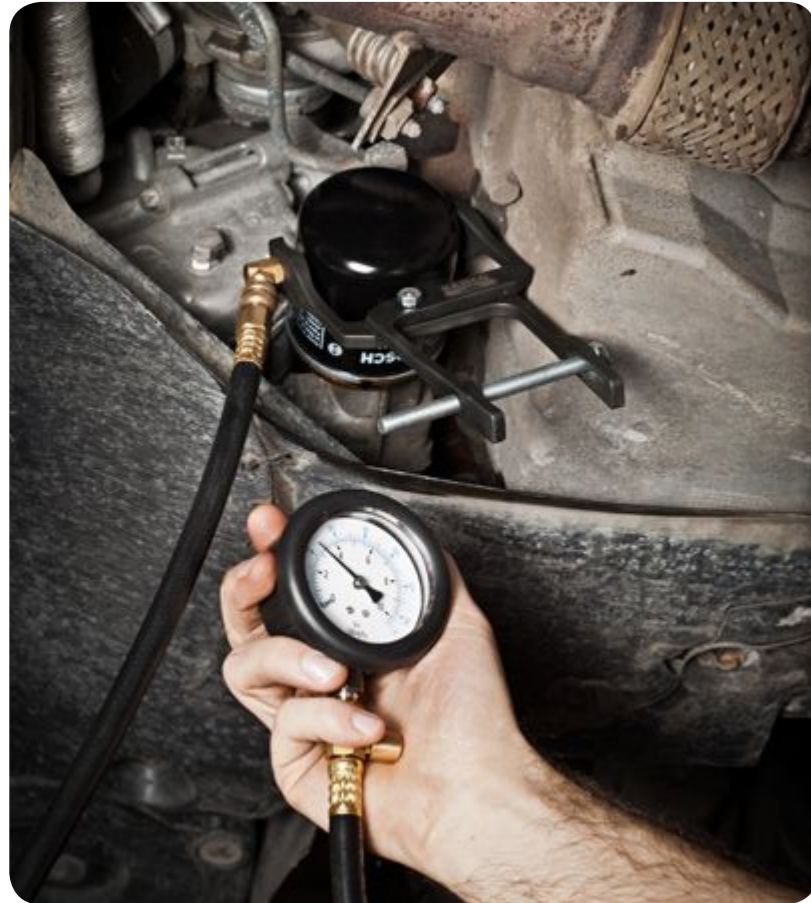

T12
348 mm x 261 mm

▶ SEAL AND SOFT HOSE REMOVAL AND PICKING TOOL SET

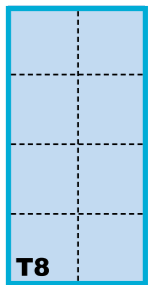

T8
348 mm x 174 mm

- Application: Check oil pressure in engine and transmission system
- Contents:
 - Pressure tester hose and gauge with BAR [0-10] and PSI [0-150]
 - 90° adaptor
 - Engine oil pressure quick test clamp [BE530001]
 - SAE adaptors [black finished]:
 - 1/2" x 20 UNF
 - 3/8" x 20 UNF
 - 1/4" x 18 NPT
 - 1/8" x 27 NPT
 - R 1/8" DIN
 - Metric adaptors [chrome finished]
 - M10 x P1,0
 - M12 x P1,5
 - M14 x P1,5
- Quick and accurate system, using adaptors or a clamp that goes directly to the oil filter
- Covers 90% of the car makes
- Supplied in a blow mould case, in foam inlay modular size T12
- Fits into the Bahco T-module inlay system for tool trolleys



- Application:
 - To remove seals and soft o-rings
 - Pick up of hoses and other objects
- Contents: 6 differently shaped and sized tools
- The different shapes and lengths of the tools included in the set allow removal of all kinds of seals, o-rings etc making the application area wide
- Supplied in a blow mould case, in foam inlay modular size T8. Fits into the Bahco T-module inlay system for tool trolleys



BE5200	84 x 447 x 341	2	2,10	7314150205905
BE530001	35 x 385 x 180	20	0,20	7314150205912

2633HD/S6	80 x 356 x 270	8	1,12	7314150205783

▶ HOSE CRAMP METALLIC



- Application: To throttle / block PVC hoses
- Can be used on most flexible hose lines of fuel, heaters, cooling systems, radiators, brakes, etc
- Easy wheel adjustment
- The length of 310 mm allows to access confine spaces

BE256M	45 x 399 x 75	20	0,26	7314150205851

▶ HOSE CRAMP PLIERS SET

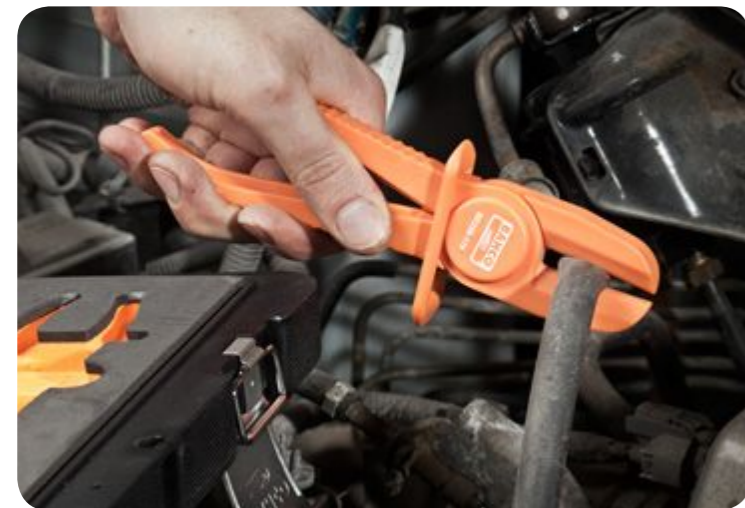

- Application: To throttle / block PVC hoses
- Contents:
 - Short size pliers 155 mm [BE256-155]
 - Medium size pliers 185 mm [BE256-178]
 - Long size pliers 250 mm [BE256-250]

- Available individually
- Can be used on most flexible hose lines of fuel, heaters, cooling systems, radiators, brakes, etc
- Material: plastic
- Easy one hand adjustment system with jaws

BE256P3	45 x 320 x 95	20	0,28	7314150205868
BE256-155	45 x 220 x 95	40	0,12	7314150205875
BE256-178	45 x 240 x 95	40	0,07	7314150205882
BE256-250	45 x 320 x 95	20	0,04	7314150205899

▶ QUICK FLUID STOPPER AND INJECTOR HOSE SEPARATOR SET

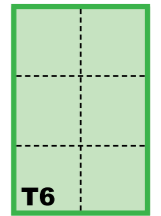

174 mm x 261 mm

	X 2 PCS		3/16" 1/4" 5/16"
BE25718	Ø mm 18	BE2576	
BE25710	10.4		
	X 1 PC		
BE2572	Ø8.8	BE256-178	

- Application: Stops fluid loss and seals off pipes and hoses while working on the engine and ancillaries
- Contents:
 - Hose clamp pliers 185 mm [BE256-178]
 - Set of 1 stopper of each of the following sizes: 3/16", 1/4", 5/16" [BE2576]
 - Banjo fitting clamp ø 18 mm [BE25718]
 - Metal fuel pipe ø 10,4 mm [BE25710]
 - Fuel pipe separator ø 8,8 mm [BE2572]
- The tools are designed to suit a variety of pipes and hoses including fuel lines, transmission fluid lines, coolant lines, vacuum lines, etc
- Supplied in a blow mould case, in foam inlay modular size T6; Fits into the Bahco T-module inlay system for tool trolleys

COMPONENTS AND SPARE PARTS

- BE256-178 / Hose clamp pliers 185 mm
- BE2576 / Set of 1 stopper of each of the following sizes: 3/16", 1/4", 5/16"
- BE25718 / Banjo fitting clamp ø 18 mm
- BE25710 / Metal fuel pipe ø 10,4 mm
- BE2572 / Fuel pipe separator ø 8,8 mm



BE257	80 x 272 x 228	8	0,85	7314150205844

► COOLING SYSTEM PRESSURE TESTER SET



- Application: Allows to test for leaks in the cooling system on a wide range of engines in a quick and simple manner
- Contents:
 - Pressure testing pump with gauge [0- 2.5 BAR / 0-350 PSI] and quick coupling
 - Thermometer (0°- 200°C)
 - 16 ABS colour coded adaptors
 - 1 ABS wrench for adaptor tightening
 - 3 metallic adaptors
 - 2 universal car cap testing adaptors
- Universal, large coverage [see application chart]
- Operation: insert pressure in the system
 - If the pressure is maintained there is no leak
 - If the pressure is lost, there is a leak
- All components have quick couplings for increased safety and reduced time of operation
- Supplied in a blow mould case, in foam inlay for a better tool control



BE400P2404	Cadillac (Catera: 1997-2001) Daewoo (All: 1999-2011) Ford (Contour: 1995-200) (Fiesta: 1995-)(Focus:1998-)(Fusion: 2006-) GM (Achiva – Skylark – Grand Am: 1992-2002) Jaguar (All: 1990-1994) (X-Type: 2002-) Jeep Land Rover (Discovery: 1989-2004) (Range Rover: 1998-1994) Mercedes Benz (ML-class - W163 – W164) Mercury (Mystique: 1995-2000) Pontiac (Le Mans: 1988-1993) Porsche (911: 199-)(Boxter: 1997-) Saab (900: 1994-1998) Saturn (L-Series: 2000-)
BE400P2405	Alfa Romeo Citroën Fiat Mini Cooper (S: 2002-) Peugeot (206: 1999-)(307: 2004-)(406: 1999-)(407: 2004-)(807: 2004-) Renault (All: 1985-1987)(Avantime: 2002-)(Espace:2002-) Saab (900: 1978-1993)(9000: 1986-1998) Sterling (All: 1987-1991) Jeep Volvo (Passenger vehicles w/threaded neck)
BE400P2406	VW (Vento – T4 – Passat 1996 – Golf – Beetle – Sharan)(1990-1998: w/female thread on filter neck of expansion tank – except 1998 Passat and New Beetle)(Eurovan: 1990-2003) (Golf: 1993-1998)
BE400P2407	Audi (A4: 1996-)(A5)(A6: 1998-)(A8:1997)(TT:2000) BMW (345) Porsche (Cayenne)
BE400P2408	VW (Beetle: 1998-)(Golf: 1999-)(Jetta: 1999-)(Passat: 1998-) BMW (3 Series: 1998-)(5 Series: 1997-2003) (7 Series: 1998-) (E46 – E36 – E34 – E39 – E38 – E32 – E90)
BE400P2409	Audi (1975-1993: w/male thread on expansion tank) VW (Beetle: 1975-1993: w/male thread on expansion tank)(Golf: 1983-1992)
BE400P2410	Ford (Mondeo) International Land Rover Opel Ssangyong Motor
BE400P2411	Chrysler (Crossfire: 2004-) Mercedes Benz (w/ thread filler neck on expansion tank, except M-Class)(E-Class: 1996-) (C-Class – E-Class – S-Class – W140 – W220 – W124 – W210 – W211 – W215 – W216 – W221 – R230)
BE400P2412	Ford (Mondeo: 2000-2007), Focus (2000-2007), C-Max (2003)
BE400P2413	Ford (Focus)(Mondeo 2008, 2009) Mazda (M3 2004-2009)
BE400P2414	Mercedes Benz (A-Class [W168])
BE400P2415	BMW (E60, E63, E65)
BE400P2416	VW (Sharan 1.8T 2.8)
BE400P2417	Toyota (Celica: 2000-VW – RAV4 – Previa)(MR2 Spyder: 2000-)
BE400P2418	Saab Echo
BE400P2419	Lincoln (Mark VIII: 1993-1998)(Navigator: 1997-)(Towncar: 1993-) Mercedes (M-Class: 1998-) Mercury (Cougar: 1993-1997: w/ V8)(Grand Marquis: 1993-2003)(Milan: 2006-) (Mountaineer: 2002-)(Sable: 1996-) Oldsmobile (Achieva: 1992-1998)(Alero: 1999-)(Aurora: 1995-)(Cutlass: 1997-1998) Intrigue (1999-) Pontiac (Firebird: 199-2002)(Grand Am: 1992-)(Grand Prix: 2004-) (GTO: 2004-)(Sunfire: 1995-) Saturn (All: 1990-);Buick (Roadmaster:1994-1996)(Skylark: 1992-1998) Cadillac (CTS: 2003-)(Escalade: 1999-)(Fleetwood: 1994-1996)(Seville: 1998-) Chevrolet (Beretta: 1992-1996)(Camaro: 1999-2002) (Caprice: 1994-1996)(Cavalier: 1995-)(Corsica: 1992-1996)(Corvette: 1999-)(Impala: 1994-)(Malibu: 1997-)(Metro: 1999-) (Prizm: 1999)(Silverado: 1999-)(Tahoe: 1999-)(Tracker: 1999-) Ford (Crown Victoria: 1993-2003)(E Series Vans: 1995-)(Excursion: 2000-)(Expedition: 1997-)(Explorer: 2002-)(F Series Trucks: 1995-)(Five Hundred: 2005-)(Taurus: 1996) (Thunderbird: 1993-1997)(Thunderbird: 2002-) GMC (Envoy: 1998-)(Sierra: 1999-)(Yukon: 1999-) Hummer (H2: 2003-)

BE400P2401	Buick (LeSabre 1990-)(Park Avenir 1991-) Chrysler (Sebring 1995-) Chevrolet (Venture 1997-) Dodge (Caravan 1989-)(Dakota 1989-)(Stratus 1995-) Jeep Mercedes Benz (W123 – W126 – W124 – W201) Oldsmobile (Silhouette 1990-) Pontiac (Bonneville 1990-)(Grand Prix – 2003)
BE400P2402	Acura (Integra: 1990-1993); Chevrolet (Nova: 1985-1998)(Spectrum: 1985-1988) (Sprint: 1985-1988) Chrysler (Laser: 1991-1996); Dodge (Colt: 1984-1992)(Stealth: 1991-1996) Eagle (Talon: 1991-1998) Ford (Escort: 1991-)(Explorer: 1995-2001)(Festiva: 1988-1993) (Probe: 1989-1997)(Ranger: 1967-) (Tempo: 1992-1994)(Windstar: 1995-)(Thunderbird: 1989-1992; 1993-1997: w/VA) Geo (Metro: 1989-1994)(Prizm: 1998)(Tracker: 1989-1993); GM (Nova, Spectrum, Sprint) Honda (Accord: 1990-1993)(Civic: 1988-1991)(Motorcycles: 1991-2004)(Passport: 1994-) (Prelude: 1990-1998) Hyundai (All: 1987-); Kia (Sedona: 2003-) Infiniti (All: 1992-); Isuzu (All: 1992-1997) Lexus (LS 400: 1990-1999)(LX 450: 1996-1999)(LX 470: 1996-1999)(ES: 1994-1999) Mazda (All: 1985-1999), not 1995 Protege w/1.5L)(MPV: 1990-) Mercury (Cougar: 1989-1992)(Cougar: 1993-1997 bw/V6)(Topaz: 1992-1994)(Tracer: 1991-1999)(Villager: 1993-)(Villager: 1995-1999) Mitsubishi (3000GT: 1991-1998)(Diamante: 1992-1995)(Galant: 1985-1993) (Mirage: 1985-1992)(Montero: 1989-1998)(Starion: 1989-1993) Mercedes Benz Nissan (All: 1987-); Subaru (All: 1964-);Suzuki (1983-1995 w/16 mm deep neck) Peugeot Toyota (Corolla: 1983-1992)(Starlet: 1983-1984)(Tacoma: 1995-)(Tercel: 1983-1990) (4Runner: 1986-1995)(Avalon: 1995-)(Camry: 1983-1989)(Cressida: 1985-1992)(Camry: 1983-1989)(Land Cruiser: 1987-)(Pickup: 1983-1992)(Solara: 1998-)(Sienna: 1998-1999) (Supra: 1986-1992: not turbo)(T100: 1995-1998)(Camry: 1990-1991)(Previa: 1989-1997) (Avalon: 1995-)(Camry: 1994-1999: 4 cylinder)(Celica: 1982-1989)
BE400P2403	Acura (CL: 1997-)(Integra: 1994-1999)(Legend: 1991-1996)(MDX: 2001-)(TL: 1995-) Chevrolet (Metro: 1998)(Prizm: 1998)(Tracker: 1998-) Dodge (Colt: 1993-1994) Eagle (Summit: 1993-1995) Geo (Metro: 1995-1998)(Prizm: 1998-)(Prizm: 1993-1997)(Tracker: 1994-1998) Honda (Accord: 1994-)(Civic: 1991-)(Odyssey: 1995-)(Pilot: 2003-) Isuzu (All: 1998-) Lexus (GS400: 1998-1999)(ES250: 1990-1991)(ES300: 1992-1993)(GS300: 1993-1999) Mercedes Benz (ML-class – W163 – W164) Mitsubishi (Diamante: 1996-)(Galant: 1994-)(Mirage: 1993-)(Montero Sport: 1997-) Suzuki (1989-1999: w/9mm deep neck)(XL-7: 2001-) Toyota (4Runner: 1989-)(Camry: 1990-1991: V6 w/ auto.trans.)(Camry: 1992-) (Celica: 1990-1998)(Corolla: 1993-)(Echo:2000-)(Paseo: 1992-1997)(RAV4: 1996-) (Supra: 1990-1992 turbo)(Tercel: 1991-1999)



BE400P2421 Pressure Testing Pump with Gauge



BE400P242 Connector R123/R124



BE400P2423 Connector R123/R125

► COOLING SYSTEM REFILLER, VACUUM

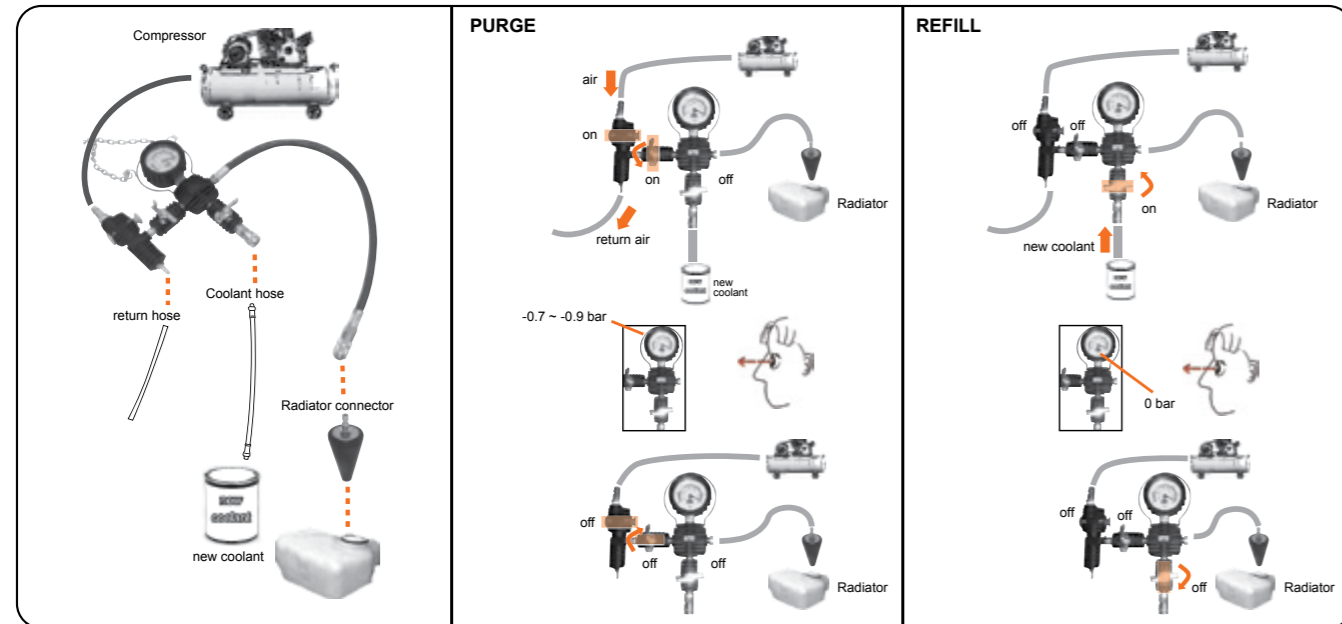

- Application: Allows to refill radiators/ cooling systems with coolant without introducing air into the system
- Contents:
 - Main device
 - Hose for coolant
 - Conic adaptor
- The conic adaptor makes the system universal, it covers the majority of the car makes
- Quick couplers enable the operator to do the job in a safe and rapid way
- Pneumatic and venturi system driven
- Supplied in a blow mould case, in foam inlay for a better tool control

► UNIVERSAL TWIN CAMSHAFT LOCKING TOOL



- Application: Lock the camshaft when disassembling parts of the engine
- Contents: 1 universal tool
- Adjustable to two different lengths, allowing a wider coverage
- Small levers on the screws facilitate a quick tightening



► CRANKSHAFT AND CAMSHAFT SEAL INSTALLER SET

Bolt Attachment	mm	Seal Attachment	mm
	Ø8		Ø68
	Ø10		Ø64
	Ø12		Ø60
	Ø14		Ø58
	Ø16		Ø56
	Ø18		Ø52
	Ø20		Ø49
			Ø48
			Ø46
			Ø42
			Ø34
			Ø28

Extension Caps

- Ø46 mm, 15mm height
- Ø46 mm, 23mm height
- Ø46 mm, Min: 33mm, Max: 50mm height
- Ø14.5 mm, 10mm height
- Ø24.5 mm, 10mm height
- Ø24.5 mm, 10mm height



- Application: to install the seals in camshafts and crankshafts
- Contents:
 - 7 bolt attachments
 - 6 extension caps
 - 12 seal attachments
- Universal
- With this set the job gets done easily, quick and in a safe way
- Supplied in a blow mould case, in foam inlay modular size T8. Fits into the Bahco T- module inlay system for tool trolleys



▶ CLUTCH ALIGNMENT RECTIFIER



174 mm x 261 mm



- Application: Aligns the clutch plate by tapered cone fitting into pilot bushing or bearing
- Contents:
 - Guide/shank [2 pcs]
 - 8 adaptors of sizes 11 mm, 15 mm, 16,5 mm, 17 mm, 19 mm, 20 mm, 20,5 mm and 25 mm
- Suitable to be used with the majority of single clutch driven vehicles
- Supplied in a blow mould case, in foam inlay modular size T6. Fits into the Bahco T-module inlay system for tool trolleys

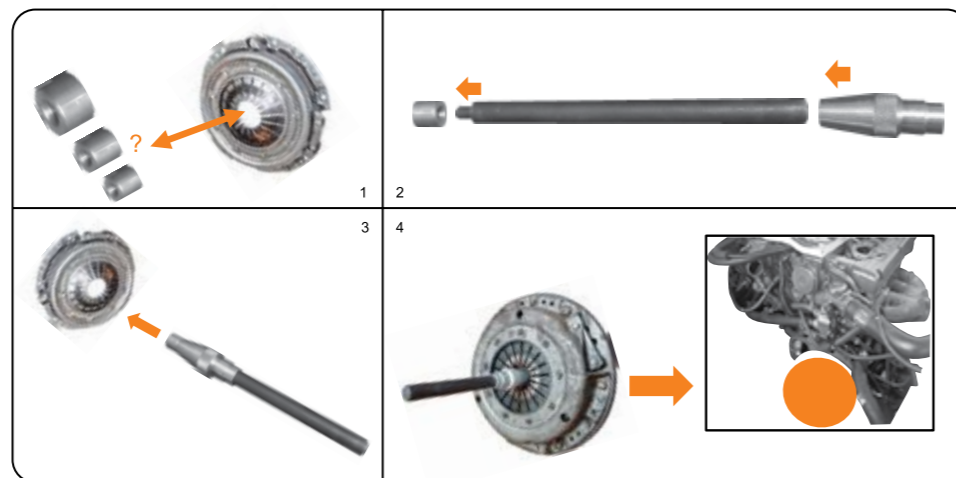

▶ GASKET JOINTS SEPARATOR SET



- Application: Allows the separation of gasket joints and other parts easily and without damaging them
- Contents:
 - Blade support
 - 2 blades
 - Wheels
 - Wheel support
 - Tube
- Metallic and copper blades included to allow work on materials of different hardness without damaging them
- Wheels for final surface cleaning
- Supplied in a blow mould case, in foam inlay for a better tool control

COMPONENTS AND SPARE PARTS

- BE700BP2 / Gasket joints cleaner blades set, 2 pcs
- BE700SP15 / Gasket joints cleaner wheels set, 15 pcs



▶ STUD REMOVER AND INSTALLER SET

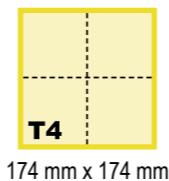
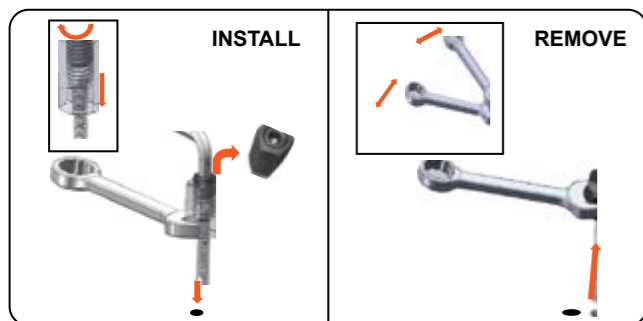

- Application: Allows for easy and quick removal and installation of studs from / in any kind of engine or machine
- Contents:
 - 4 removing tools: M6 x 1,0P, M8 x 1.25P, M10 x 1,25P, M10 x 1,5P
 - 4 installing tools: M6 x 1,0P, M8 x 1.25P, M10 x 1,25P, M10 x 1,5P
- Supplied in a blow mould case, in foam inlay modular size T4
 Fits into the Bahco T-module inlay system for tool trolleys

COMPONENTS AND SPARE PARTS

- 1411AUP81 / Stud remover/installer M6 x 1,0
- 1411AUP82 / Stud remover/installer M8 x 1,25
- 1411AUP83 / Stud remover/installer M10 x 1,25
- 1411AUP84 / Stud remover/installer M10 x 1,5



▶ AC REPAIRING TOOL SET

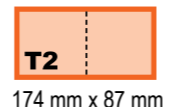

- Application: For installation and removal of the air conditioning ECU, Airflow/Mass sensors, injection pumps, etc
- Contents:
 - Hex bit holder
 - Tamper TORX® plus bits: TP10H, TP15H, TP20H, TP25H
 - Sockets: 8PT x 12 mm and 8PT x 15 mm
 - Special bit 2,2 mm and 3,2 mm
- 1/4" drive
- Covers the majority of the car makes
- Supplied in a blow mould case, in foam inlay modular size T2
 Fits into the Bahco T-module inlay system for tool trolleys

1/4" 3,2 mm 2,2 mm	1/4" 8PT x 12 8PT x 15
1/4" H6.35	1/4" Length: 25 mm TP10H TP15H TP20H TP25H TP27H TP30H TP40H



▶ TORX® TAMPER 1/2" SOCKET WITH BIT, SUITABLE FOR ENGINES

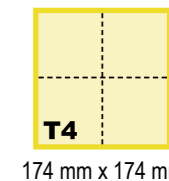

- Application: To tighten / untighten Tamper TORX® screws, widely used in engines
- Contents: bits in sizes T25, T27, T30, T40, T45, T50, T55, T60, T70
- Drive: 1/2"
- Supplied in a blow mould case, in foam inlay modular size T4
 Fits into the Bahco T-module inlay system for tool trolleys

COMPONENTS AND SPARE PARTS

- BE510125 / T25
- BE510127 / T27
- BE510130 / T30
- BE510140 / T40
- BE510145 / T45
- BE510150 / T50
- BE510155 / T55
- BE510160 / T60
- BE5049T70HL / T70

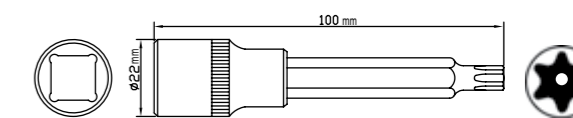

▶ RIBE 1/2" SOCKET WITH BIT, SUITABLE FOR ENGINES

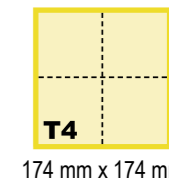

- Application: To tighten / untighten RIBE screws, widely used in engines
- Contents: bits in sizes RM5, RM6, RM7, RM8, RM9, RM10, RM11, RM12, RM13
- Drive: 1/2"
- Supplied in a blow mould case, in foam inlay modular size T4
 Fits into the Bahco T-module inlay system for tool trolleys

COMPONENTS AND SPARE PARTS

- BE51025 / RM5
- BE51026 / RM6
- BE51027 / RM7
- BE51028 / RM8
- BE51029 / RM9
- BE510210 / RM10
- BE510211 / RM11
- BE510212 / RM12
- BE510213 / RM13

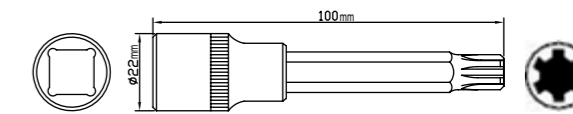

► XZN 1/2" SOCKET WITH BIT, SUITABLE FOR ENGINES

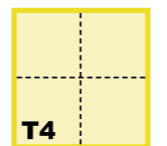

174 mm x 174 mm

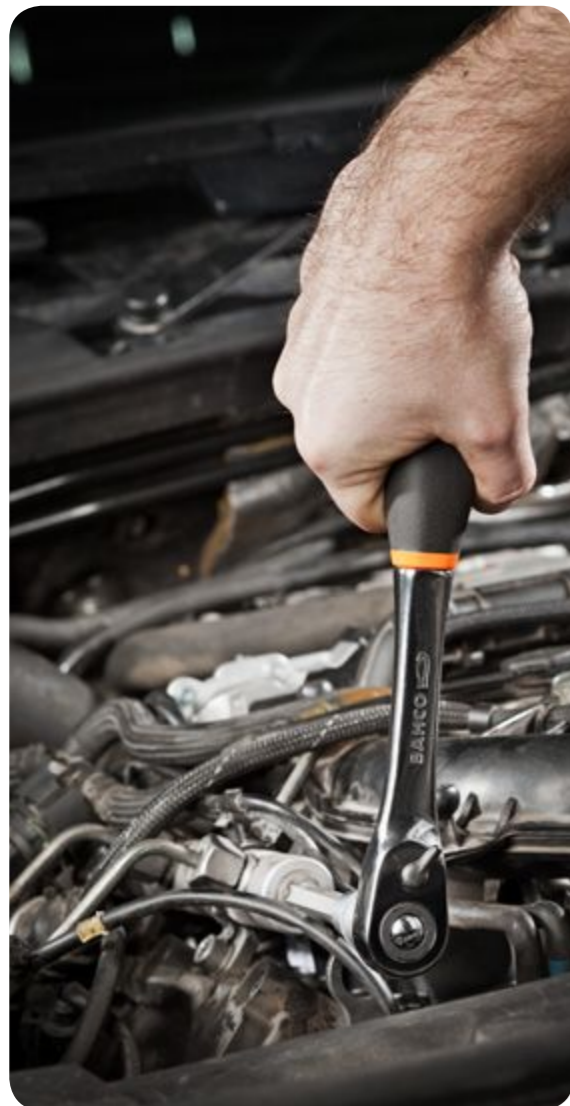

- Application: To tighten / untighten XZN screws, widely used in engines
- Contents: bits in sizes M5, M6, M8, M10, M12, M14
- Drive: 1/2"
- Supplied in a blow mould case, in foam inlay modular size T4
Fits into the Bahco T-module inlay system for tool trolleys

COMPONENTS AND SPARE PARTS

- BE51035 / M5
- BE51036 / M6
- BE51038 / M8
- BE510310 / M10
- BE510312 / M12
- BE510314 / M14

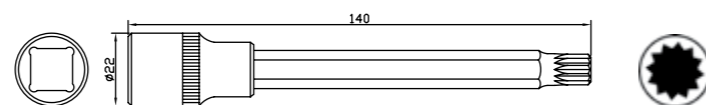

02

BRAKE TOOLS

► TORX® 1/2" IMPACT SOCKET BIT SET FOR BRAKES

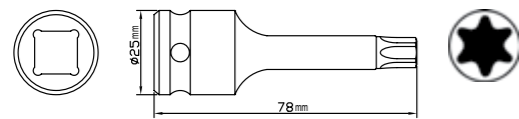

- Application: For various applications when servicing and working on the brake system using power tools
- Contents: T20, T25, T27, T30, T40, T45, T50, T55, T60
- Supplied in a blow mould case, in foam inlay modular size T4; Fits into the Bahco T-module inlay system for tool trolleys

COMPONENTS AND SPARE PARTS

- BBR203P920 / TORX® 1/2" Impact Socket Bit for Brakes, T20
- BBR203P925 / TORX® 1/2" Impact Socket Bit for Brakes, T25
- BBR203P927 / TORX® 1/2" Impact Socket Bit for Brakes, T27
- BBR203P930 / TORX® 1/2" Impact Socket Bit for Brakes, T30
- BBR203P940 / TORX® 1/2" Impact Socket Bit for Brakes, T40
- BBR203P945 / TORX® 1/2" Impact Socket Bit for Brakes, T45
- BBR203P950 / TORX® 1/2" Impact Socket Bit for Brakes, T50
- BBR203P955 / TORX® 1/2" Impact Socket Bit for Brakes, T55
- BBR203P960 / TORX® 1/2" Impact Socket Bit for Brakes, T60

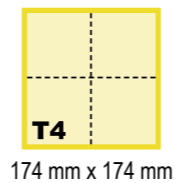

174 mm x 174 mm



► XZN 1/2" IMPACT SOCKET BIT SET FOR BRAKES

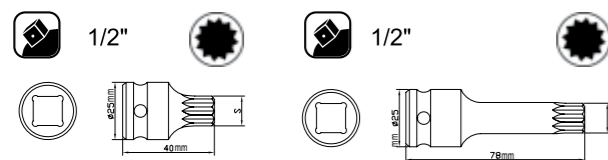

- Application: For various applications when servicing and working on the brake system using power tools
- Contents:
 - 40 mm long sockets: M14, M16 and M18
 - 78 mm long sockets: M14, M16 and M18
- Supplied in a blow mould case, in foam inlay modular size T4; Fits into the Bahco T-module inlay system for tool trolleys

COMPONENTS AND SPARE PARTS

- BB201P64014 / XZN 1/2" Impact Socket Bit for Brakes, M14
- BB201P64016 / XZN 1/2" Impact Socket Bit for Brakes, M16
- BB201P64018 / XZN 1/2" Impact Socket Bit for Brakes, M18
- BB201P67814 / XZN 1/2" Impact Socket Bit for Brakes, M14
- BB201P67816 / XZN 1/2" Impact Socket Bit for Brakes, M16
- BB201P67818 / XZN 1/2" Impact Socket Bit for Brakes, M18

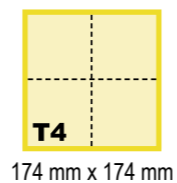

174 mm x 174 mm



► 1/2" PENTAGON SOCKET AND BIT SET FOR HAND BRAKE

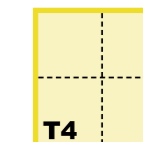

174 mm x 174 mm

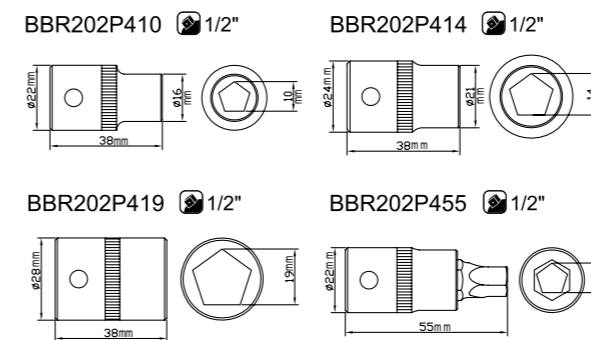

- Application: For servicing of cars' hand brake system
- Contents:
 - Sockets: 10 mm, 14 mm and 19 mm
 - Socket bit: 10 mm
- Covers the majority of the car makes and can be easily used with a pneumatic ratchet
- Supplied in a blow mould case, in foam inlay for better tool storage

COMPONENTS AND SPARE PARTS

- BBR202P410 / Pentagon 1/2" Socket, 10 mm
- BBR202P414 / Pentagon 1/2" Socket, 14 mm
- BBR202P419 / Pentagon 1/2" Socket, 19 mm
- BBR202P455 / Pentagon 1/2" Socket Bit, 10 mm



► SHOE BRAKE SPRINGS REMOVING AND INSTALLATION SET

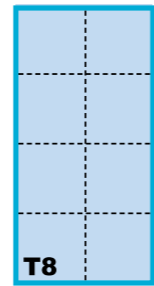

T8
348 mm x 174 mm



- Application: For removal and installation of compressed springs in the brakes
- Contents:
 - Pliers [BBRS210P]
 - Blade with curved and u-shaped tip for pushing springs [BBRS210P2]
 - Straight blade with 90 degrees angle and hook for pulling springs [BBRS210P2]
- The set makes the application completely safe and quick
- Can be used for any other application where spring removal or installation is needed
- Supplied in a blow mould case, in foam inlay modular size T4
 Fits into the Bahco T-module inlay system for tool trolleys

COMPONENTS AND SPARE PARTS

- BBRS210P / Shoe brake spring remover pliers
- BBRS210P2 / 1 Blade with curved and u-shaped tip for pushing springs and 1 Straight blade with 90 degrees angle and hook for pulling springs

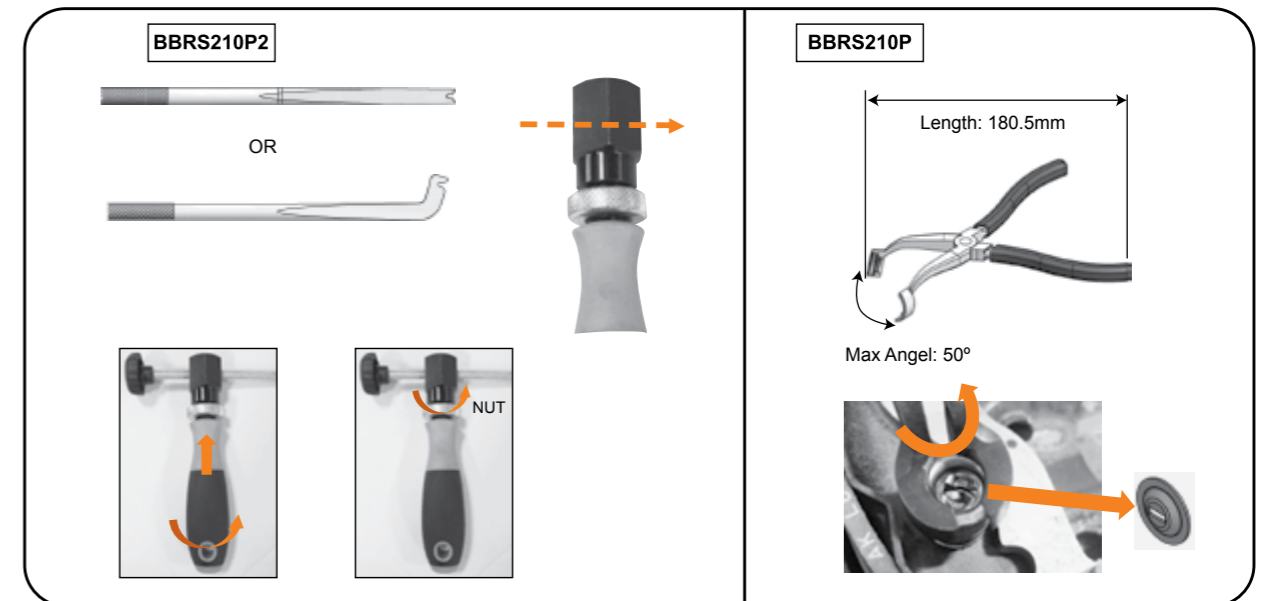

03

**TRANSMISSION
& WHEEL
TOOLS**



► BEARING REMOVING AND INSTALLING SET

Installation

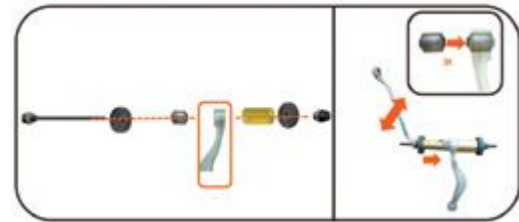

Removal

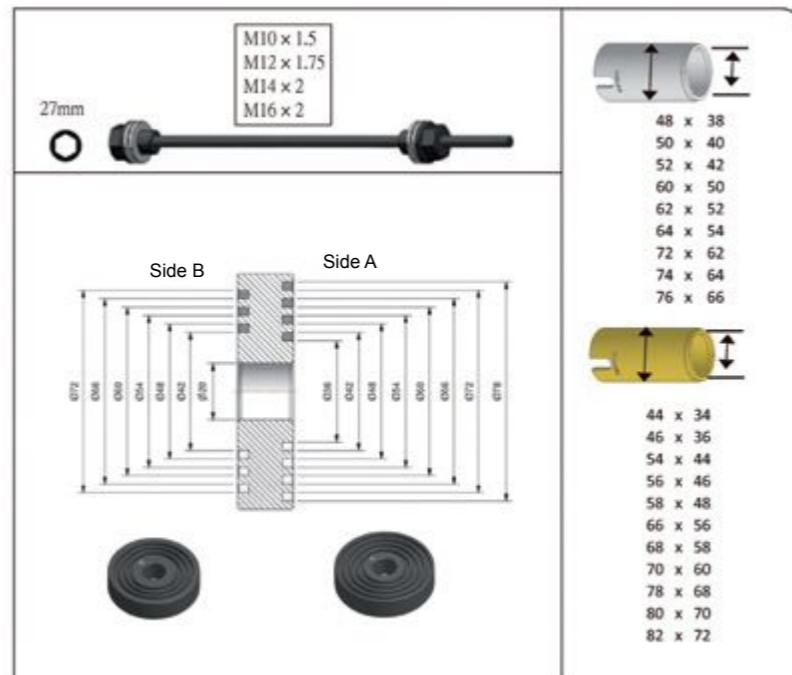

• Application: For removal and installation of different bearings, ball bearings and seals

• Contents:

- 4 spindles
- 20 sleeves
- 2 plate discs for presses

• Features a uniquely designed u-shape on every sleeve which enables the mechanic to easily watch the working process and assure that the bearings are installed in the right place

BT20P26

155 x 540 x 315

26

19,0

7314150205820

► MULTI POSITIONING RATCHETING PRY BAR SET



- Application: For removal and adjustment of seals, bearings and manifolds as well as drive shafts, axles and fuel injectors
- Contents: 3 different sized pry bars
 - 250 mm / 10" [BT10P325]
 - 300 mm / 12" [BT10P330]
 - 380 mm / 15" [BT10P338]
- The bars can be easily adjusted through a push button in the handle which controls the locking and releasing mechanism of the head
- The head can be adjusted into 14 positions
- Supplied in a blow mould case, in foam inlay modular size T8
Fits into the Bahco T-module inlay system for tool trolleys

COMPONENTS AND SPARE PARTS

- BT10P325 / Multi Position Ratcheting Pry Bar, 250 mm / 10"
- BT10P330 / Multi Position Ratcheting Pry Bar, 300 mm / 12"
- BT10P338 / Multi Position Ratcheting Pry Bar, 380 mm / 15"

BT10P3

80 x 356 x 270

8

1,90

7314150205639

► 1/2" IMPACT SOCKET AND BIT SET

1/2"	S	ØD	L
BT15P514	14mm	26	42
BT15P517	17mm	26	42

1/2"	S	ØD	L
BT15P524	24mm	34	45
BT15P530	30mm	42	45
BT15P532	32mm	44	45



- Application: Commonly used for hub assembly or disassembly, especially in VAG vehicles
- Contents:
 - Hex socket bits: 14 mm and 17 mm
 - XZN sockets: 24 mm, 30 mm and 32 mm
- Supplied in a blow mould case, with foam inlay for better tool storage

COMPONENTS AND SPARE PARTS

- BT15P514 / 1/2" Bit, 14 mm
- BT15P517 / 1/2" Bit, 17 mm
- BT15P524 / 1/2" Socket, 24 mm
- BT15P530 / 1/2" Socket, 30 mm
- BT15P532 / 1/2" Socket, 32 mm



BT15P5

60 x 260 x 85

5

1,55

7314150205837

04

**SUSPENSION
TOOLS**



► MACPHERSON SPRING COMPRESSOR DEVICE

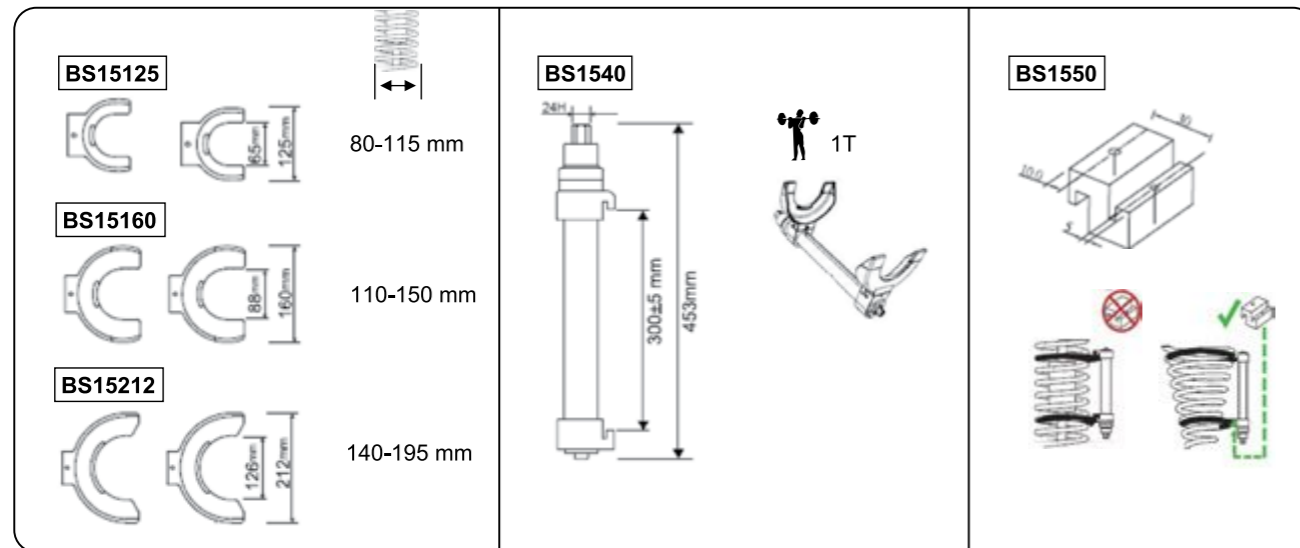

- Application: To compress MacPherson springs
- Contents:
 - Device/Piston [BS1540]
 - 3 pairs of jaws [BS15125, BS15160, BS15212]
 - Small adaptor for conic springs [BS1550]
- All components are available individually
- Universal, covers 90% of the vehicle park [3 different pairs of jaws]
- Jaws working range:
 - BS15125 : 80 - 115 mm
 - BS15160: 110 - 150 mm
 - BS15212: 140 - 195 mm
- Can be used for both straight and conic springs
- Max compression capacity: 1 T
- Max spring working range of the device: 300 mm
- The 24 mm hex head can be operated manually or with an air tool
- Spring protectors in the jaws

COMPONENTS AND SPARE PARTS

- BS1540 / Device/Piston
- BS15125 / Pair of jaws 80 - 115 mm
- BS15160 / Pair of jaws 110 - 150 mm
- BS15212 / Pair of jaws 140 - 195 mm
- BS1550 / Small adaptor for conic springs



► WISHBONE LEVER TOOL



- Application: To take out the transmission system of a vehicle by pushing down the wishbone. Very convenient when disassembling the drive shaft, replacing the gaiter or exchanging the wheel bearings
- Contents: 1 lever
- 10 different positions, making it easier to push down the wishbone and other suspension parts
- Special design of the sliding groove adjusting the position so that the operator can work in the most convenient position
- Provides increased safety
- Saves time and resources, since the work can be done quickly and by one person
- Easy storage - a hole in the end of the handle for easy storage
- Insulated handle

05

**BODYWORK
& EXHAUST
TOOLS**



► WIPER PULLER SET

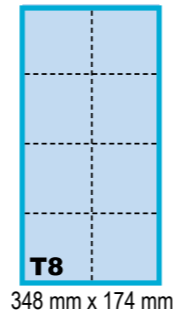

Icon	mm		
		BBS170P139	L= 98 mm
		BBS165	MIN: 5 mm MAX: 47 mm
		BE1300SH	L= 230 mm
BBS170P131	21		
BBS170P132	23,3		
BBS170P133	16,2		
BBS170P134	23,5		
BBS170P135	27,7		
BBS170P136	19,4		
BBS170P137	17,2		
BBS170P138	18,3		

- Application: Allows to remove wiper arms that are rusty or corroded onto the drive shaft
- Contents:
 - 8 different profile grippers / adaptors to be applied on different wipers [BBS170P131- BBS170P138]
 - 1 universal puller with 4 changeable legs [BBS165]
 - 1 pressure/ pushing spindle [BBS170P139]
 - 1 sliding hammer [BE1300SH]
 - 2 pairs of head adaptors [V and U shaped] to be used with the universal puller or pushing spindle [BBS165SP4]
- Universal set allowing many different options to extract [use the puller or the sliding hammer with the profiles]
- Stubborn and deeply seated arms can be quickly and easily removed in a safe way
- Supplied in a blow mould case, in foam inlay modular size T8
Fits into the Bahco T-module inlay system for tool trolleys

COMPONENTS AND SPARE PARTS

- BBS170P131- BBS170P138 / 8 different profile grippers / adaptors to be applied on different wipers
- BBS165 / 1 universal puller with 4 changeable legs
- BBS170P139 / 1 pressure/ pushing spindle
- BE1300SH / 1 sliding hammer
- BBS165SP4 / 2 pairs of head adaptors [V and U shaped] to be used with the universal puller or pushing spindle



Icon	mm	Qty	Weight	Part No.
	80 x 356 x 270	4	4,39	7314150205608
	55 x 290 x 75	10	1,22	7314150205585
	27 x 170 x 95	10	0,61	7314150205615

► UNIVERSAL EXHAUST REMOVING TOOL

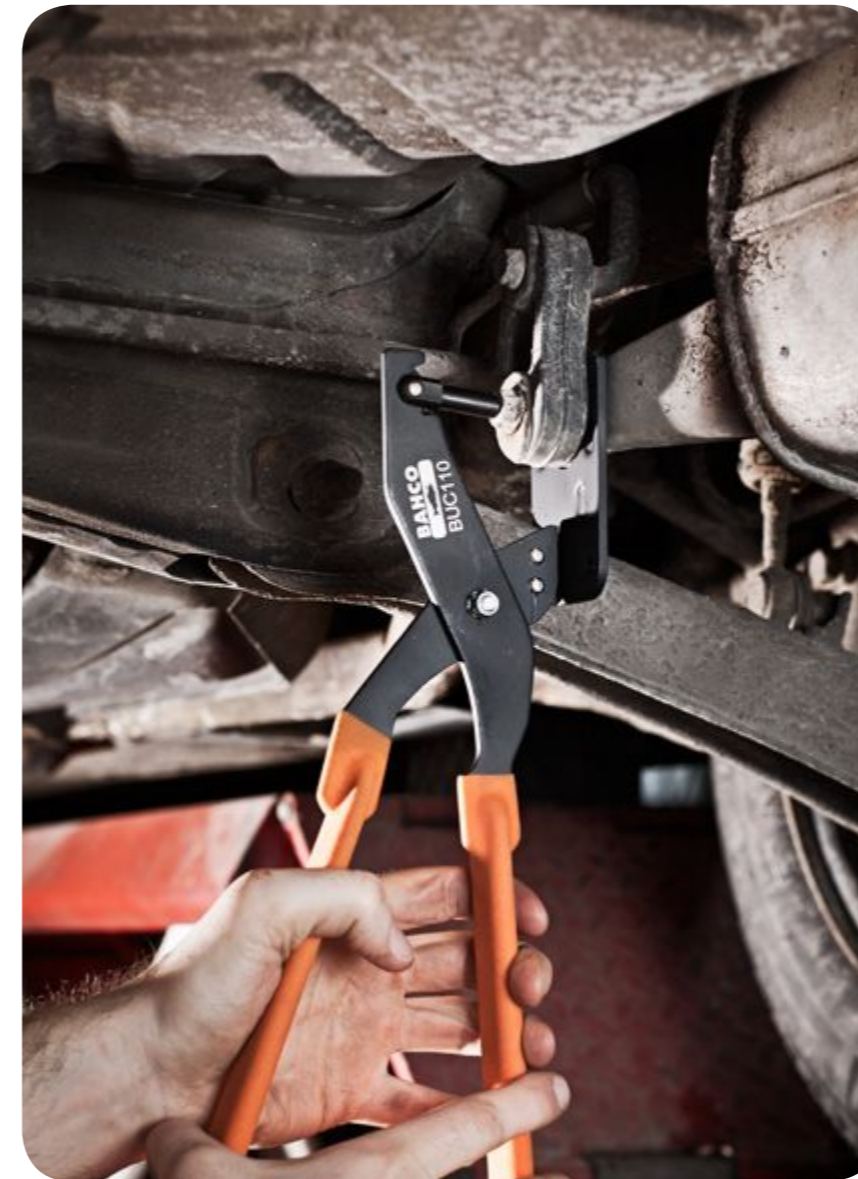

- Application: For quick, easy and safe removal of the exhaust system from its rubber hangers
- Contents: 1 universal exhaust removing tool
- Rounded holes at the handle ends for easy storage

Icon	mm	Qty	Weight	Part No.
	68 x 1,300 x 459	1	0,86	7314150206025



06

**OIL
CHANGE
TOOLS**

▶ OIL DRAINER AND REFILLER WITH CHAMBER



- Application: To drain oil by both air suction and gravity
- Included probes:
 - Flexible nylon: 5 x 700 mm, 6 x 700 mm, 7 x 1000 mm 8 x 700 mm
 - Rigid copper: 5 x 700 mm, 6 x 700 m
 - Adaptors: for BMW, VAG Group
- Reinforced connection between tank and oil tube to minimize the risk of leakages
- Swivel offset designed funnel ensures a high flexibility and capacity
- Foam protected handle for insulation and to avoid scratches on vehicles in case of an accident
- Metal reinforced hoses
- 10 L chamber for visual check of the oil status
- Liquid level gauge
- Tank pressure gauge
- One swivel wheel with brake for increased safety
- Useful plastic tray for screws, tools and others equipment

BOD8903

1000 x 480 x 440

1

38,8

7314150195060

▶ OIL DRAIN PLUG RESTORER SET

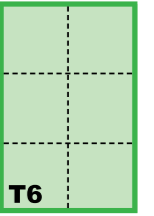

T6

174 mm x 261 mm



- Application: Provides an easy and quick way to restore damaged oil plug threads by threading a new hole and installing a new plug
- Contents:
 - BOD102 / M13 x 1.5P tap + 5 screws + 10 copper washers
 - BOD103 / M15 x 1.5P tap + 5 screws + 10 copper washers
 - BOD104 / M17 x 1.5P tap + 5 screws + 10 copper washers
 - BOD105 / M20 x 1.5P tap + 5 screws + 10 copper washers
- Includes sizes for the majority of the car makes
- Use the tap to enlarge the damaged thread and create a new profile and install the new plug
- Supplied in a blow mould case, in foam inlay modular size T6
Fits into the Bahco T-module inlay system for tool trolleys

COMPONENTS AND SPARE PARTS

- BOD102 / M13 x 1.5P tap + 6 screws + 12 copper washers
- BOD103 / M15 x 1.5P tap + 6 screws + 12 copper washers
- BOD104 / M17 x 1.5P tap + 6 screws + 12 copper washers
- BOD105 / M20 x 1.5P tap + 6 screws + 12 copper washers



BOD10P64

80 x 272 x 228

64

2,5

7314150205950

► MINI OIL DRAIN PLUG RESTORER SETS



BOD101



BOD102



BOD103



BOD104



BOD105



BOD106

- Application: Provides an easy and quick way to restore damaged oil plug threads by threading a new hole and installing a new plug
- Use the tap to enlarge the damaged thread and create a new profile and install the new plug
- Supplied in a plastic box with transparent top
- BOD101 / M13 x 1.25P tap + 6 screws + 12 copper washers
- BOD102 / M13 x 1.5P tap + 6 screws + 12 copper washers
- BOD103 / M15 x 1.5P tap + 6 screws + 12 copper washers
- BOD104 / M17 x 1.5P tap + 6 screws + 12 copper washers
- BOD105 / M20 x 1.5P tap + 6 screws + 12 copper washers
- BOD106 / M22 x 1.5P tap + 6 screws + 12 copper washers

Model	Dimensions (mm)	Weight (g)	Material	Part Number
BOD101	35 x 105 x 95	19	0,3	7314150205974
BOD102	35 x 105 x 95	17	0,28	7314150205974
BOD103	35 x 105 x 95	19	0,3	7314150205981
BOD104	35 x 105 x 95	19	0,3	7314150205998
BOD105	35 x 105 x 95	19	0,3	7314150206001
BOD106	35 x 105 x 95	19	0,3	7314150206018



ООО «ТехноВита» Россия, 443022, г. Самара, Заводское шоссе, д.1, офис 410
тел.: (846)279-23-15, 279-27-16, tvita@tvita.ru www.tvita.ru



www.bahco.com